

NAME: MDIP013025-1 THE CLIFFS

DATE:05/05/26

REINFORCING



Sheet 4 of 7

Mokkarala Prakash
Digitally signed by Mokkarala Prakash
Date: 2026.05.22 02:00:53 -05'00'

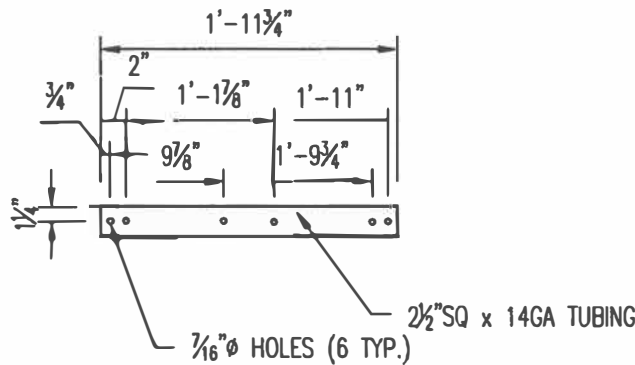

(130) PCS. REQ'D. GALV
FITS ACROSS 2' WIDE FINGER

APPROVED FOR

May 5, 2026

FABRICATION



NAME: MDIP013025-1 THE CLIFFS

DATE:05/05/26

REINFORCING

Sheet 5 of 7



Digitally signed
by Mokkarala
Prakash
Date: 2026.05.22
02:01:46 -05'00'

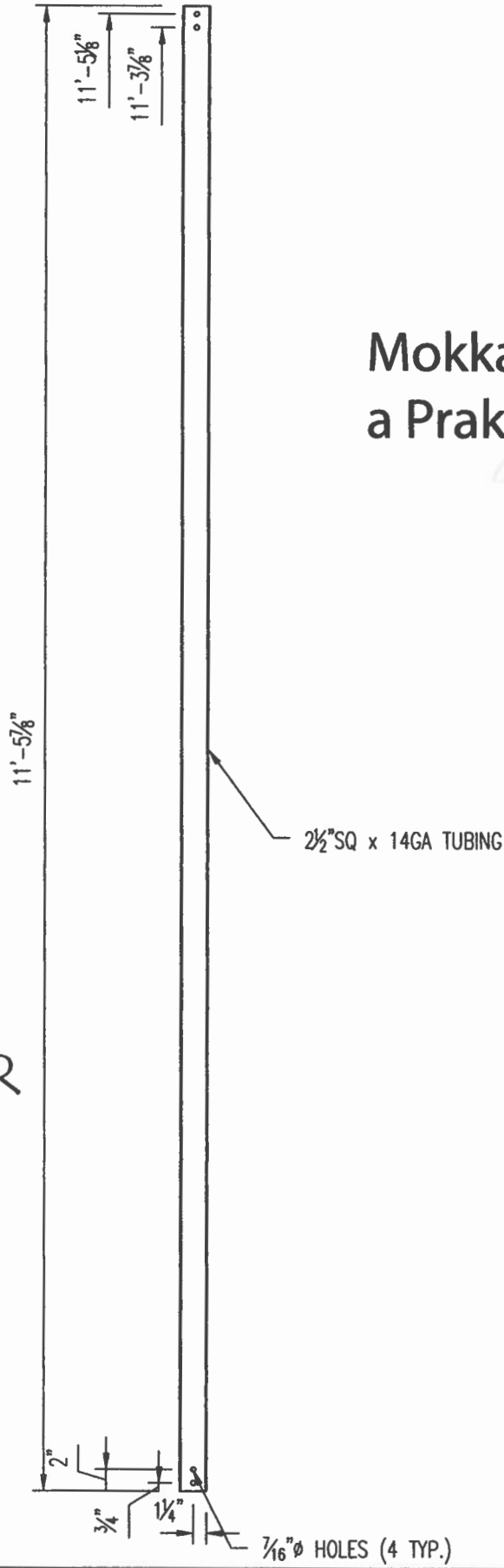

APPROVED FOR
May 5, 2026
FABRICATION
MDI

(16) PC. REQ'D. GALV
FITS 11'-8 5/8" COLUMN SPACING

NAME: MDIP013025-1 THE CLIFFS

DATE:05/05/26

REINFORCING



Sheet 6 of 7

Digitally signed
by Mokkarala
Prakash
Date: 2026.05.22
02:02:45 -05'00'

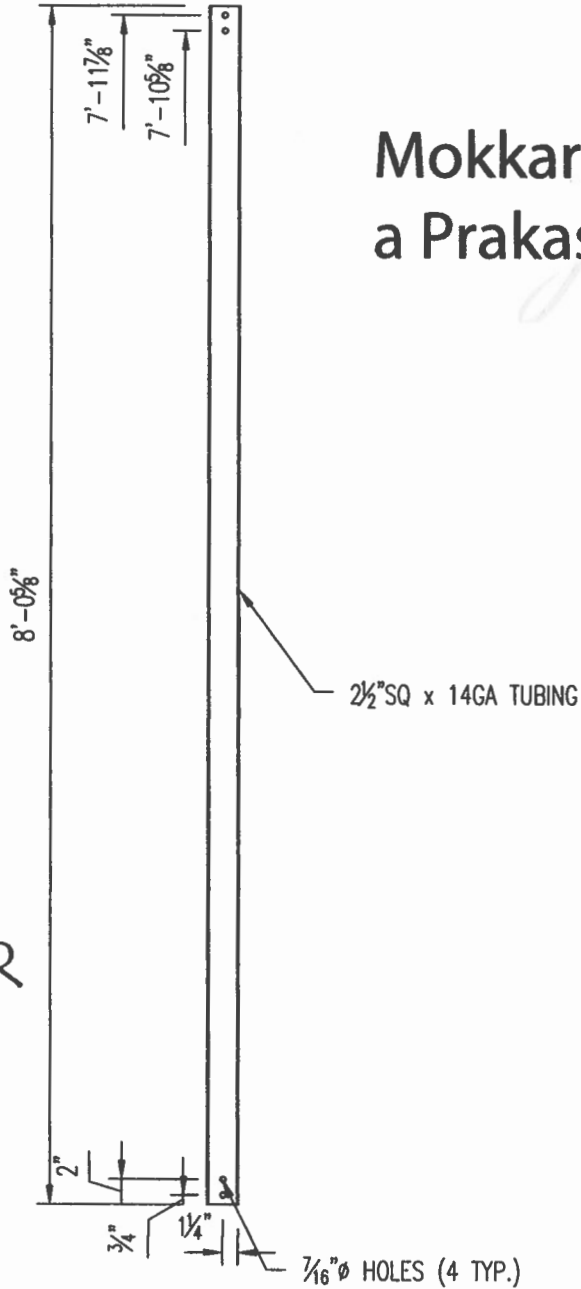

APPROVED FOR
May 5, 2026
FABRICATION
MDI

(16) PC. REQ'D. GALV
FITS 8'-3 3/8" COLUMN SPACING

NAME: MDIP013025-1 THE CLIFFS

DATE:05/05/26

REINFORCING



Sheet 7 of 7

**Mokkaral
a Prakash** Digitally signed by
Mokkarala Prakash
Date: 2026.05.22
02:03:40 -05'00'

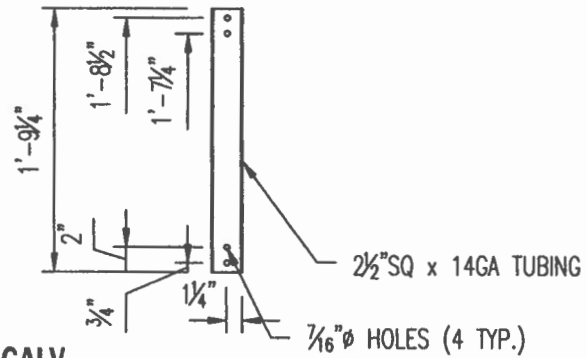

(2) PCS. REQ'D. GALV
FITS 2'-0" COLUMN SPACING

APPROVED FOR

May 5, 2026

FABRICATION



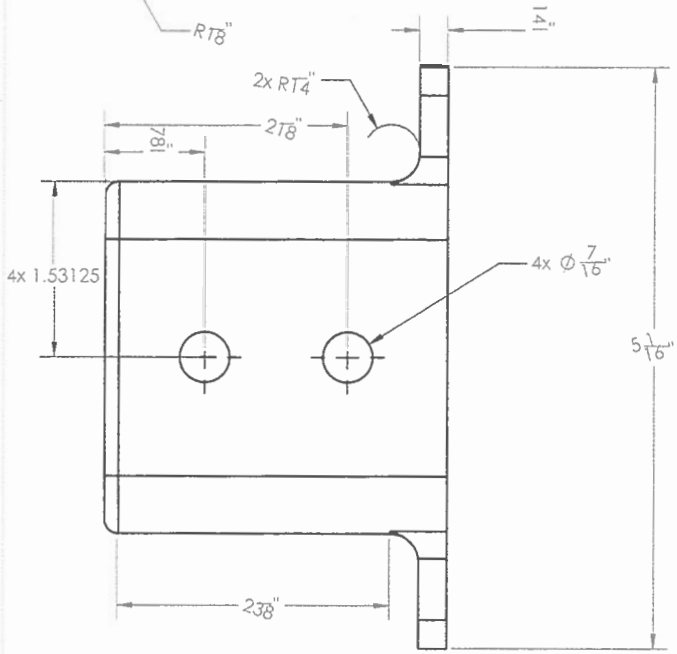
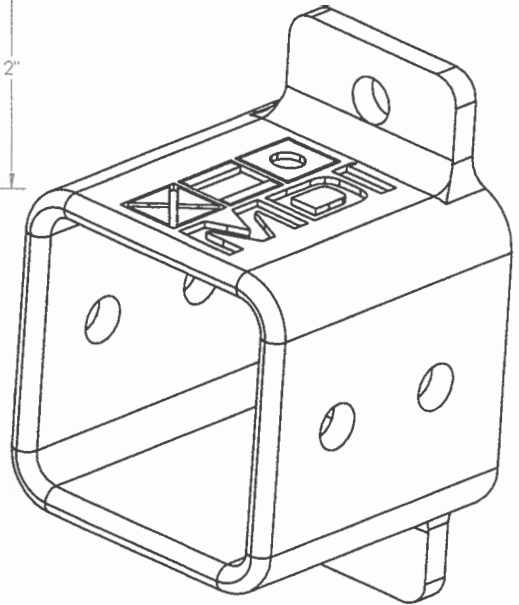
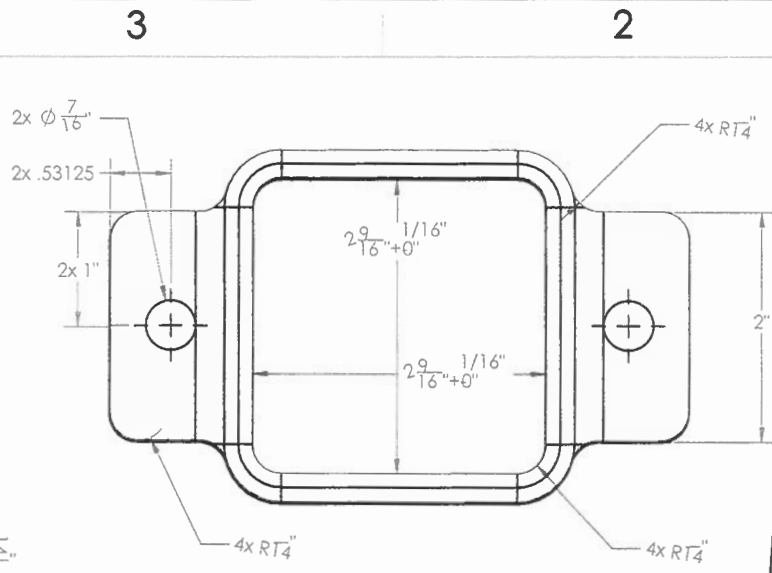
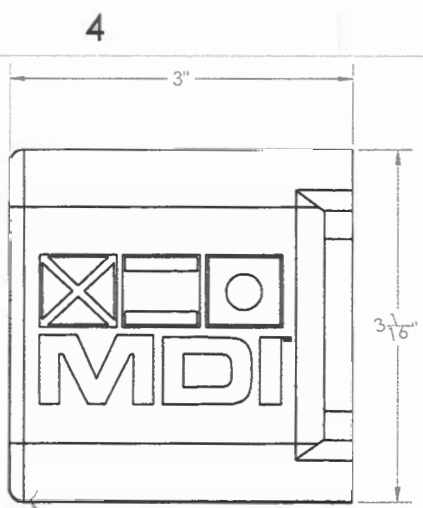

Digitally signed by Mokkarala Prakash
 Date: 2026.05.22 02:04:40 -05'00'

488 PCS. REQ'D.

UNLESS OTHERWISE SPECIFIED:

| NAME | DATE |
|-----------|------|
| DRAWN | |
| CHECKED | |
| ENG APPR | |
| MFG APPR | |
| Q.A. | |
| COMMENTS: | |

DIMENSIONS ARE IN INCHES
 TOLERANCES:
 FRACTIONAL ±
 ANGULAR: MACH2 BEND ±
 TWO PLACE DECIMAL ±
 THREE PLACE DECIMAL ±

INTERPRET GEOMETRIC TOLERANCING PER:
 MATERIAL
 FINISH
 DO NOT SCALE DRAWING

PROPRIETARY AND CONFIDENTIAL
 THE INFORMATION CONTAINED IN THIS DRAWING IS THE SOLE PROPERTY OF
 «INSERT COMPANY NAME HERE». ANY REPRODUCTION IN PART OR AS A WHOLE WITHOUT THE WRITTEN PERMISSION OF «INSERT COMPANY NAME HERE» IS PROHIBITED.

TITLE:
MaV-Req Systems
 Cast Reinforcing Bracket - Double

SIZE DWG. NO. REV
B

SCALE: 1:1 WEIGHT: SHEET 1 OF 1

NAME: MDIP013025-1 THE CLIFFS
DATE:05/05/26
PURLIN SIZE: 8"X3½"
GAUGE : 16 ☒ 14 ☐
SHEET 1 OF 2

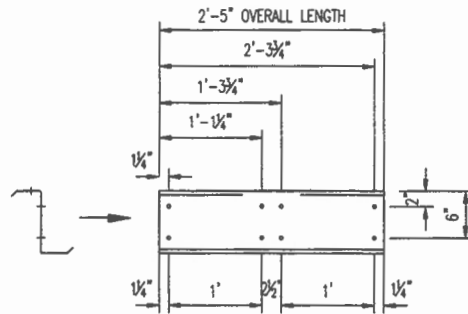

VIEW LOOKING AT
FACE P1 MAKE: 130

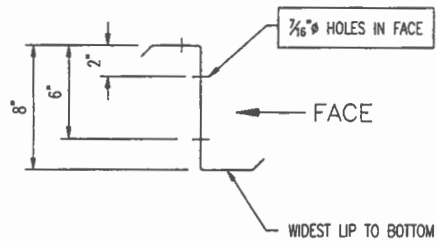

PURLINS OVER FINGERS



Mokkaral
a Prakash

Digitally signed by
Mokkarala Prakash
Date: 2026.05.22
02:05:40 -05'00'

NAME: MDIP013025-1 THE CLIFFS

DATE:05/05/26

PURLIN SIZE: 8"X3½"

GAUGE : 16 ☒ 14 □

SHEET 2 OF 2

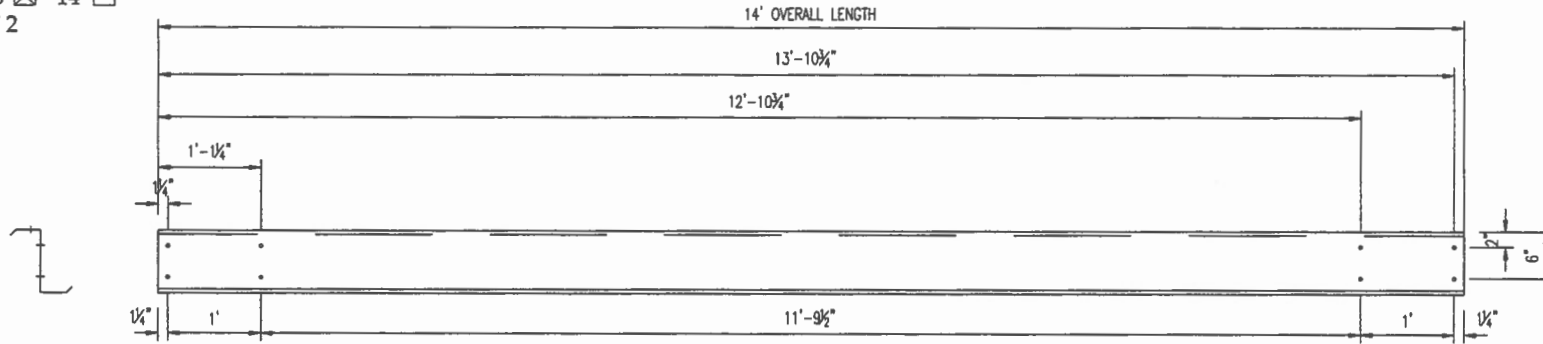

VIEW LOOKING AT
FACE P2 MAKE: 120

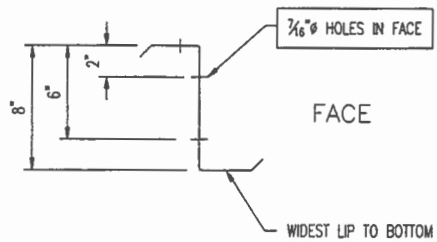

PURLINS OVER SLIPS



Mokkarala
Prakash

Digitally signed by
Mokkarala Prakash
Date: 2026.05.22 02:06:39
-05'00'

ALUMINUM SIDE MT. DECK CLEAT FOR 2" ANGLE FRAME

THE CLIFFS
 JOB: MDIPO13025-2

05/05/26

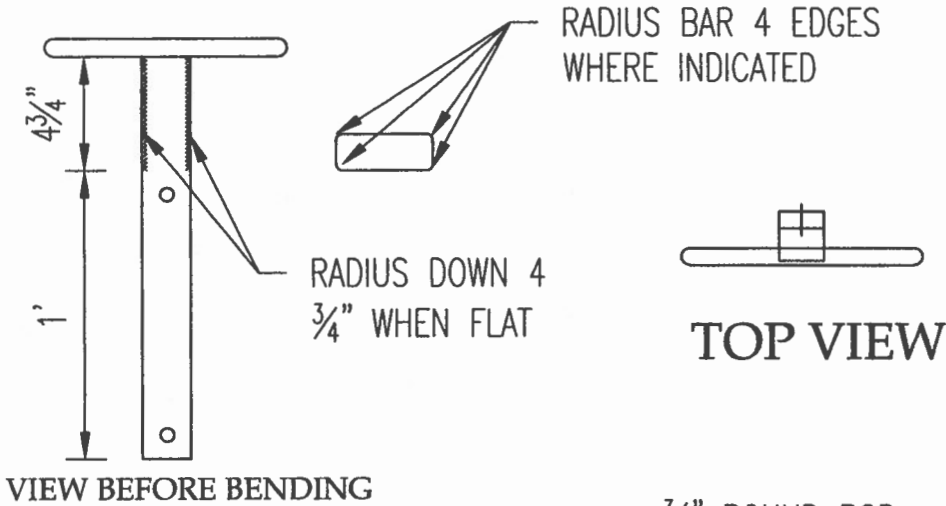

Mokkaral a Prakash Digitally signed by Mokkarala Prakash
 Date: 2026.05.22 02:09:20 -05'00'

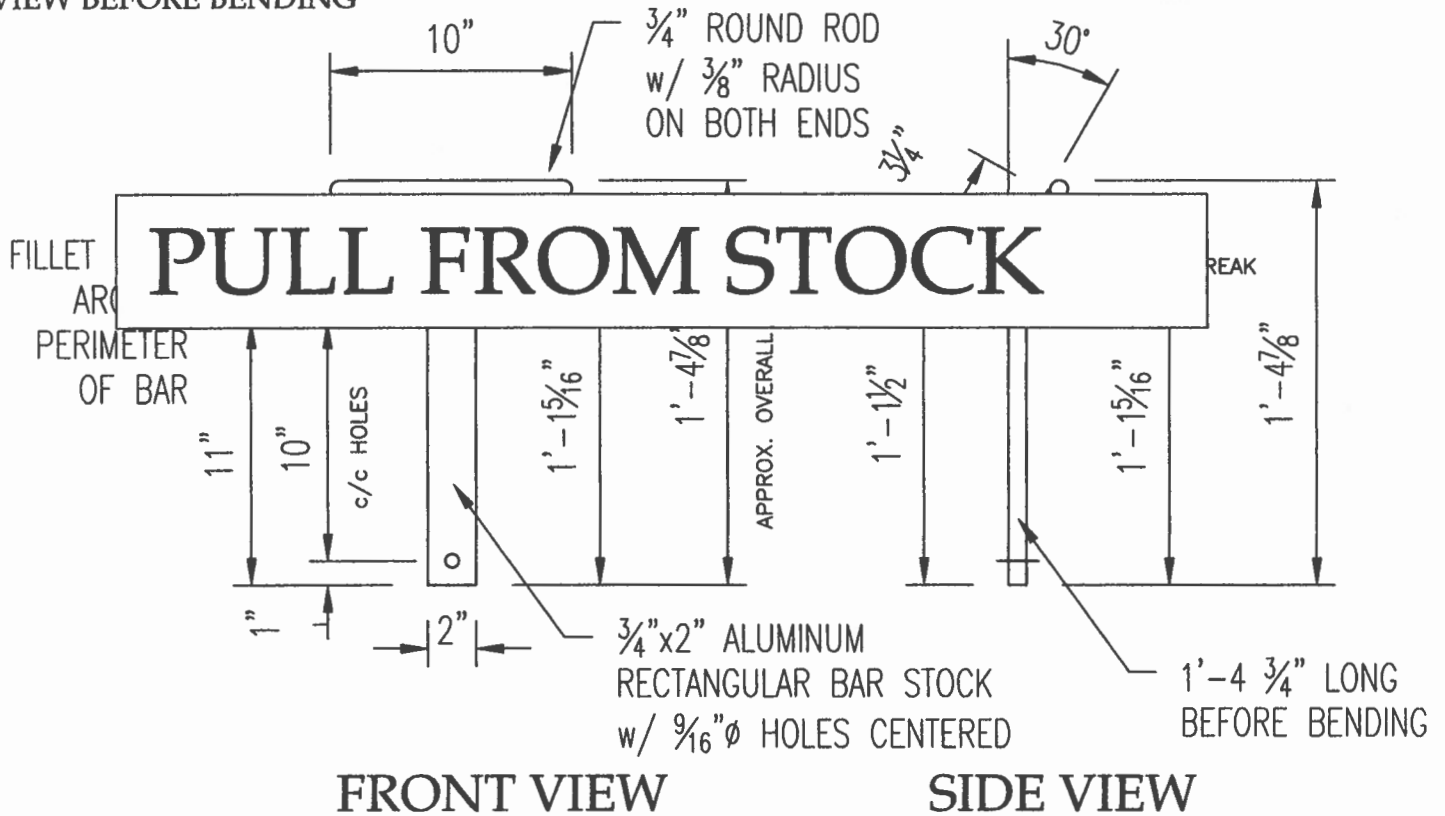

APPROVED FOR

May 5, 2026

FABRICATION 128 PCS. REQUIRED - ALUMINUM



UNDERWATER ANGLE ADAPTER

JOB: THE CLIFFS MARINA
- MDIP013025-2

DATE: 0/00/00

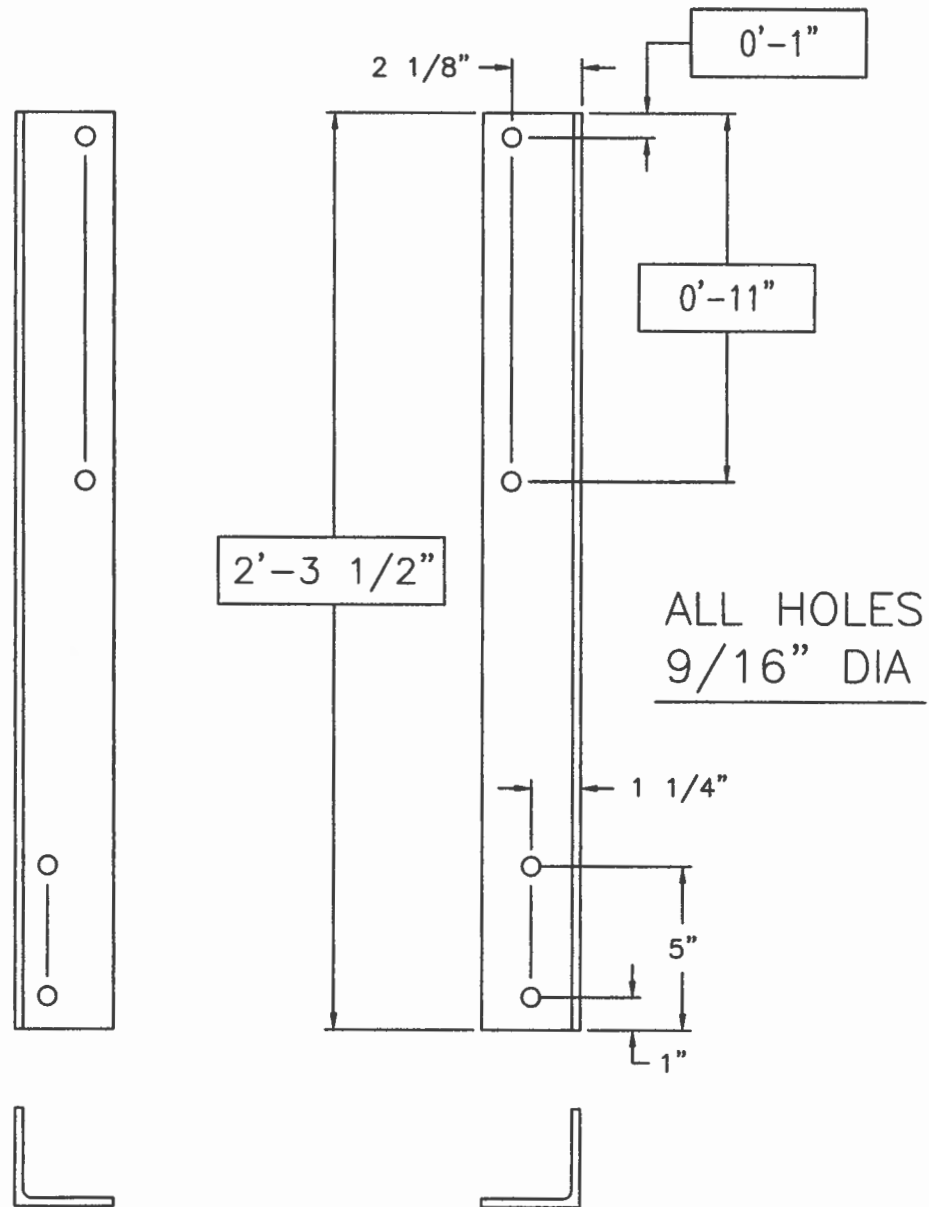

Mokkarala Prakash
 Digitally signed by Mokkarala Prakash
 Date: 2026.05.22 02:10:24 -05'00'

68 PCS - 3" x 3" x 3/16" ANGLE

34 PAIRS

UWT-2

UNDERWATER TRUSS BRACES

THE CLIFFS MARINA
JOB: - MDIPO13025-2

DATE: 05/05/26

52 PIECES - 1 1/2" x 3/16" STRAP

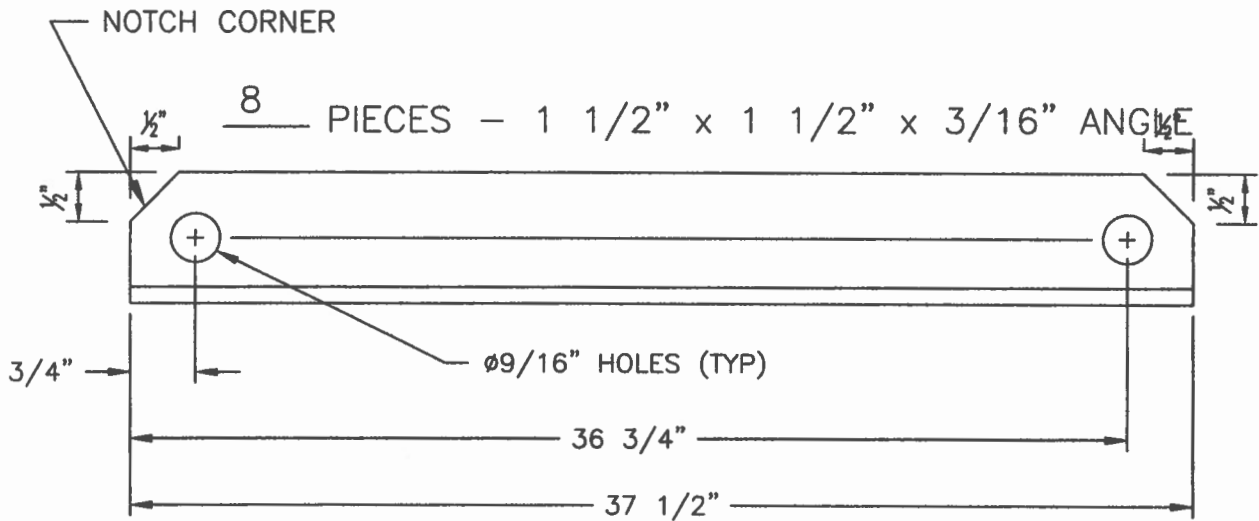
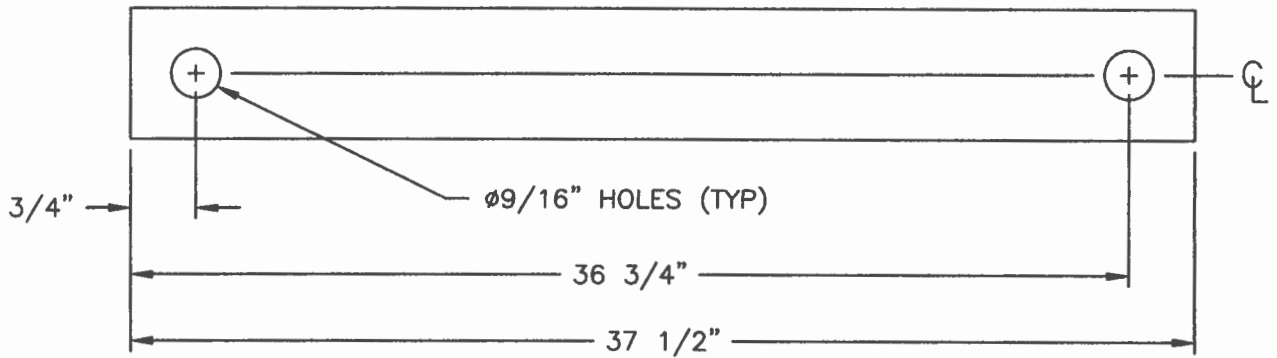

Mokkarala Prakash

Digitally signed by Mokkarala
Prakash
Date: 2026.05.22 02:11:31 -05'00'

UWT-3

UNDERWATER COLUMNS

THE CLIFFS MARINA
JOB: - MDIP013025-2

DATE: 05/05/26

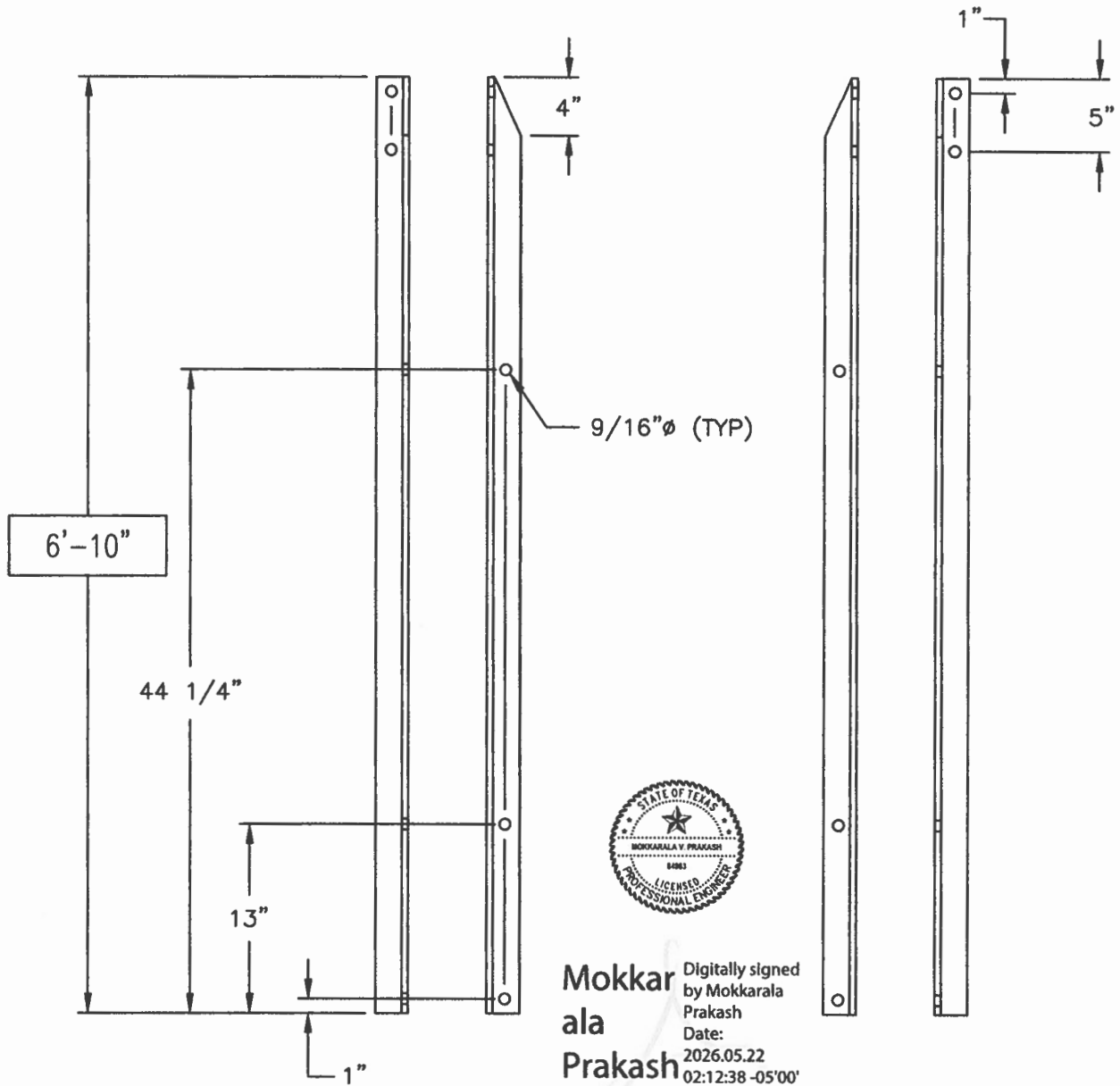

68 PCS - 2" x 2" x 3/16" ANGLE
34 PAIRS

UWT-4

UNDERWATER TRUSS HOLES

THE CLIFFS MARINA
JOB: — MDIP013025-2

DATE: 05/05/26

TRUSS

PIECE # HOLE LOCATIONS

| | | |
|---|-------|--|
| A | 4 PCS | 0'-1", 2'-3", 12'-7", 14'-1", 16'-3", 17'-9", OVERALL 20'-0" |
| B | 4 PCS | 6'-7", 8'-1", 10'-3", 11'-9" OVERALL 20'-0" |
| C | 4 PCS | 0'-7", 4'-3", 5'-9", 14'-7", 16'-1", 18'-3", 19'-9" OVERALL 20'-0" |
| D | 4 PCS | 8'-7", 10'-1", 12'-3", 13'-9", OVERALL 20'-0" |
| E | 4 PCS | 2'-7", 4'-1", 6'-3", 7'-9", 16'-7", 18'-1" OVERALL 20'-0" |
| F | 2 PCS | 0'-3", 1'-9", 10'-7", 12'-1", 14'-3", OVERALL 14'-4" |
| G | 2 PCS | 2'-7", 4'-1", 6'-3", 7'-9", 16'-7", 18'-1", 20'-3" OVERALL 20'-4" |



**Mokkaral
a Prakash** Digitally signed by
Mokkarala Prakash
Date: 2026.05.22
02:14:50 -05'00'

BRIDGE RAIL BRACE DIAGONAL ANGLE

NAME: THE CLIFFS - BRIDGE DATE: 05/05/26



Mokkarala Prakash
 Digitally signed by Mokkarala Prakash
 Date: 2026.05.22 02:17:07 -05'00'

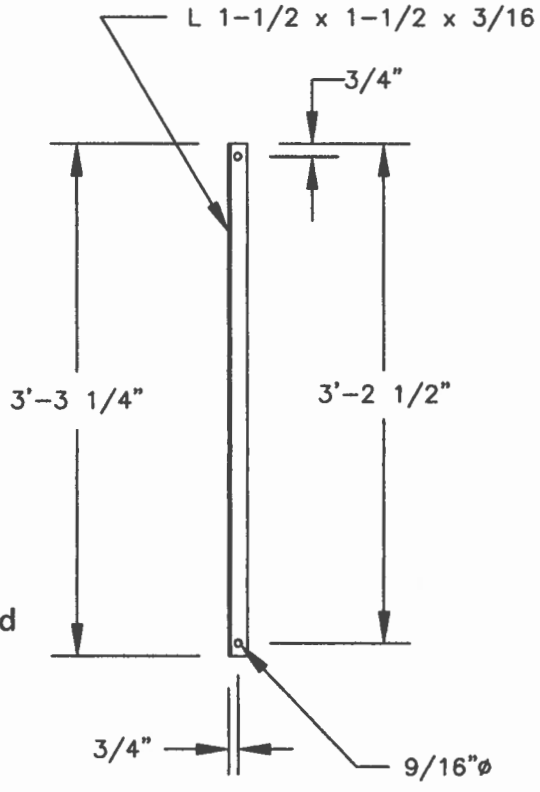

BRIDGE RAIL SIDE BRACE

| BRIDGE LENGTH | QTY REQ'D PER | TOTAL |
|---------------|---------------|-------|
| | | |
| 40' | 10 | 10 |
| | | |

BRIDGE RAIL BRACE ANGLE

NAME: THE CLIFFS - BRIDGE DATE: 05/05/26

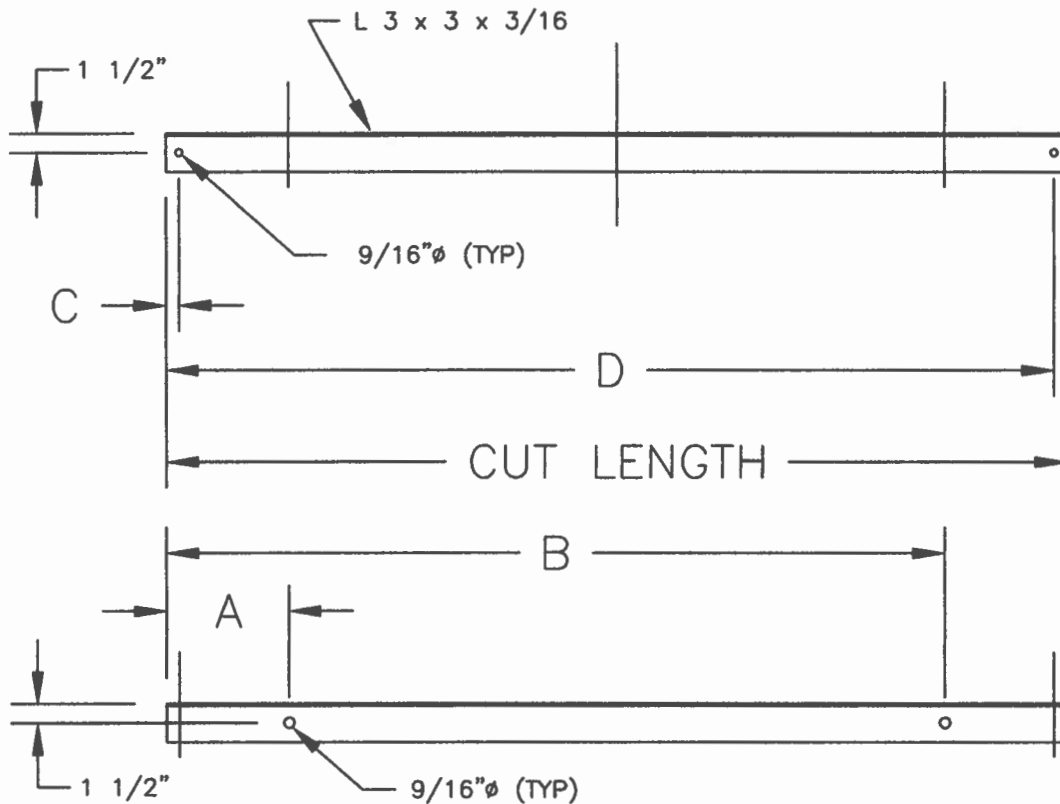

BOTTOM DIVISIONS

| ITEM | 6' WIDE BRIDGE |
|------------|----------------|
| CUT LENGTH | 7'-10" |
| A | 9 1/2" |
| B | 7'-0 1/2" |
| C | 1" |
| D | 7'-9" |

Mokkarala Prakash

Digitally signed by Mokkarala Prakash
Date: 2026.05.22
02:18:20 -05'00'



| BRIDGE LENGTH | QTY REQ'D PER | TOTAL |
|---------------|---------------|-------|
| 40' | 5 | 5 |
| | | |
| | | |

STANDARD BRIDGE (2 1/2"Ø PIPE TOP RAIL) SIDE PARTS

NAME: THE CLIFFS - BRIDGE

DATE: 05/05/26

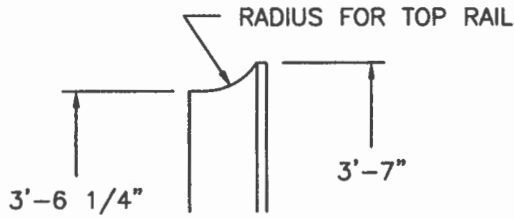

Mokkarala Prakash
 Digitally signed by Mokkarala Prakash
 Date: 2026.05.22 02:19:29 -05'00'

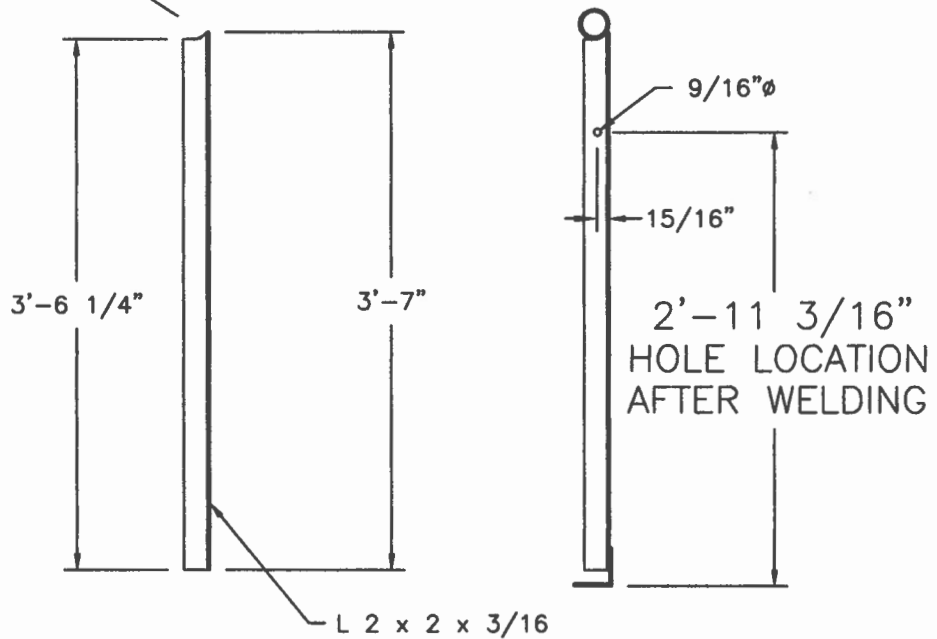

PAIRS

SIDE VERTICAL

| BRIDGE LENGTH | QTY PER SIDE | QTY PER BRIDGE | TOTAL |
|---------------|--------------|----------------|-------|
| | | | |
| 40' | 9 | 18 | 18 |
| | | | |

STANDARD BRIDGE (2 1/2"Ø PIPE TOP RAIL) SIDE PARTS

NAME: THE CLIFFS - BRIDGE

DATE: 05/05/26



**Mokkarala
Prakash**

Digitally signed by
Mokkarala Prakash
Date: 2026.05.22
02:20:41 -05'00'

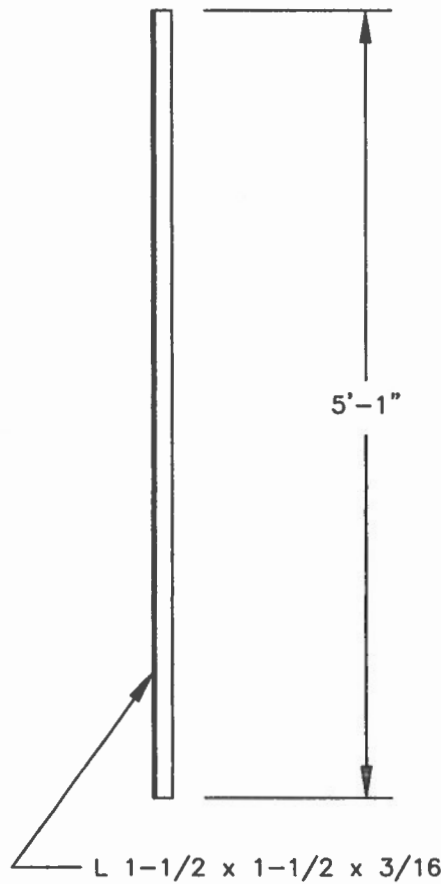

SIDE DIAGONAL

SCALE:

| BRIDGE LENGTH | QTY PER SIDE | QTY PER BRIDGE | TOTAL |
|---------------|--------------|----------------|-------|
| | | | |
| 40' | 8 | 16 | 16 |
| | | | |
| | | | |

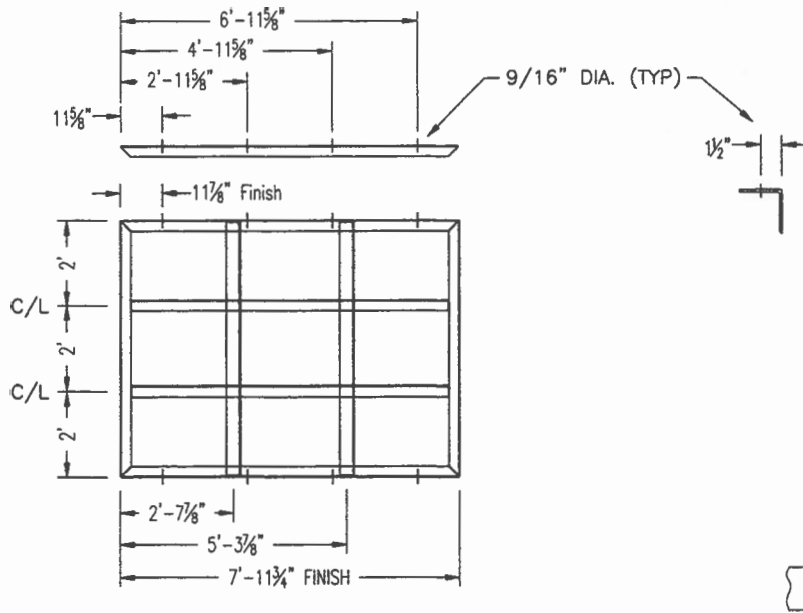

**Mokkaral
a Prakash** Digitally signed by
Mokkarala Prakash
Date: 2026.05.22
02:21:53 -05'00'

THE CLIFFS
 BRIDGE WALKWAY 6' x 8' PANELS
 05/05/26

TOTAL (3) FRAMES REQUIRED

| | NAME | FRM QTY | TLT QTY | LENGTH | MATERIAL | SPECIAL |
|---|-------------------|---------|---------|-------------|----------------|---------------------------|
| A | CORDS | 2 | | 7'-11 5/16" | L 3 x 3 x 3/16 | 4 HOLES EACH (9/16" DIA.) |
| B | DIVISIONS - END | 2 | | 5'-11 5/8" | L 3 x 3 x 3/16 | NO HOLES |
| C | DIVISIONS - ANGLE | 2 | | 5'-11" | L 4 x 4 x 1/4 | |
| D | CENTER CORD | 2 | | 7'-5 3/4" | L 3 x 3 x 3/16 | FLUSH AND NOTCH |
| E | | | | | | |
| F | | | | | | |
| G | | | | | | |
| H | | | | | | |
| I | | | | | | |

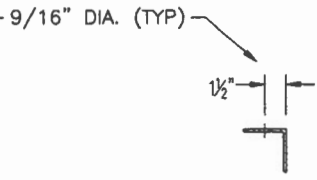
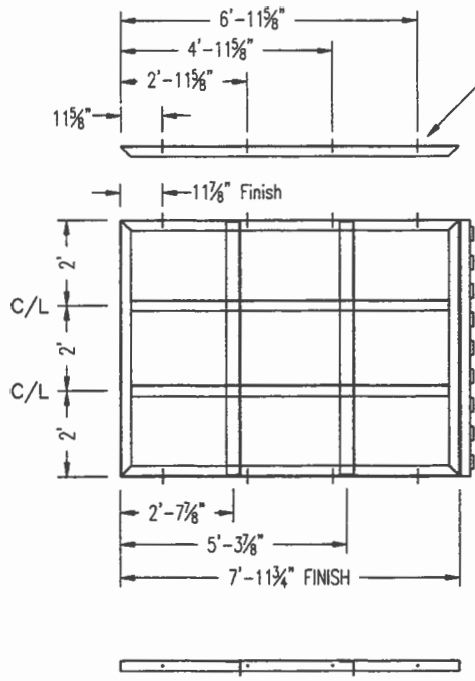

Mokkarala Prakash

Digitally signed by Mokkarala Prakash
Date: 2026.05.22 02:23:13 -05'00'

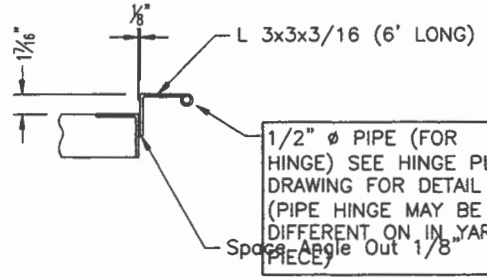

1/2" \varnothing PIPE (FOR HINGE) SEE HINGE PLATE DRAWING FOR DETAIL (PIPE HINGE MAY BE DIFFERENT ON IN-YARD PIECE)

TOTAL (2) FRAMES REQUIRED

THE CLIFFS
 BRIDGE WALKWAY 6' x 8' PANELS
 05/05/26

| | NAME | FRM QTY | TLT QTY | LENGTH | MATERIAL | SPECIAL |
|---|-------------------|---------|---------|-------------|----------------|---------------------------|
| A | CORDS | 2 | | 7'-11 5/16" | L 3 x 3 x 3/16 | 4 HOLES EACH (9/16" DIA.) |
| B | DIVISIONS - END | 2 | | 5'-11 5/8" | L 3 x 3 x 3/16 | NO HOLES |
| C | DIVISIONS - ANGLE | 2 | | 5'-11" | L 4 x 4 x 1/4 | |
| D | CENTER CORD | 2 | | 7'-5 3/4" | L 3 x 3 x 3/16 | FLUSH AND NOTCH |
| E | | | | | | |
| F | | | | | | |
| G | | | | | | |
| H | | | | | | |
| I | | | | | | |

JOB: THE CLIFFS - BRIDGE

DATE: 05/05/26

MAKE: 10 (FOR 6' x 40' BRIDGE 10 PER X 1)

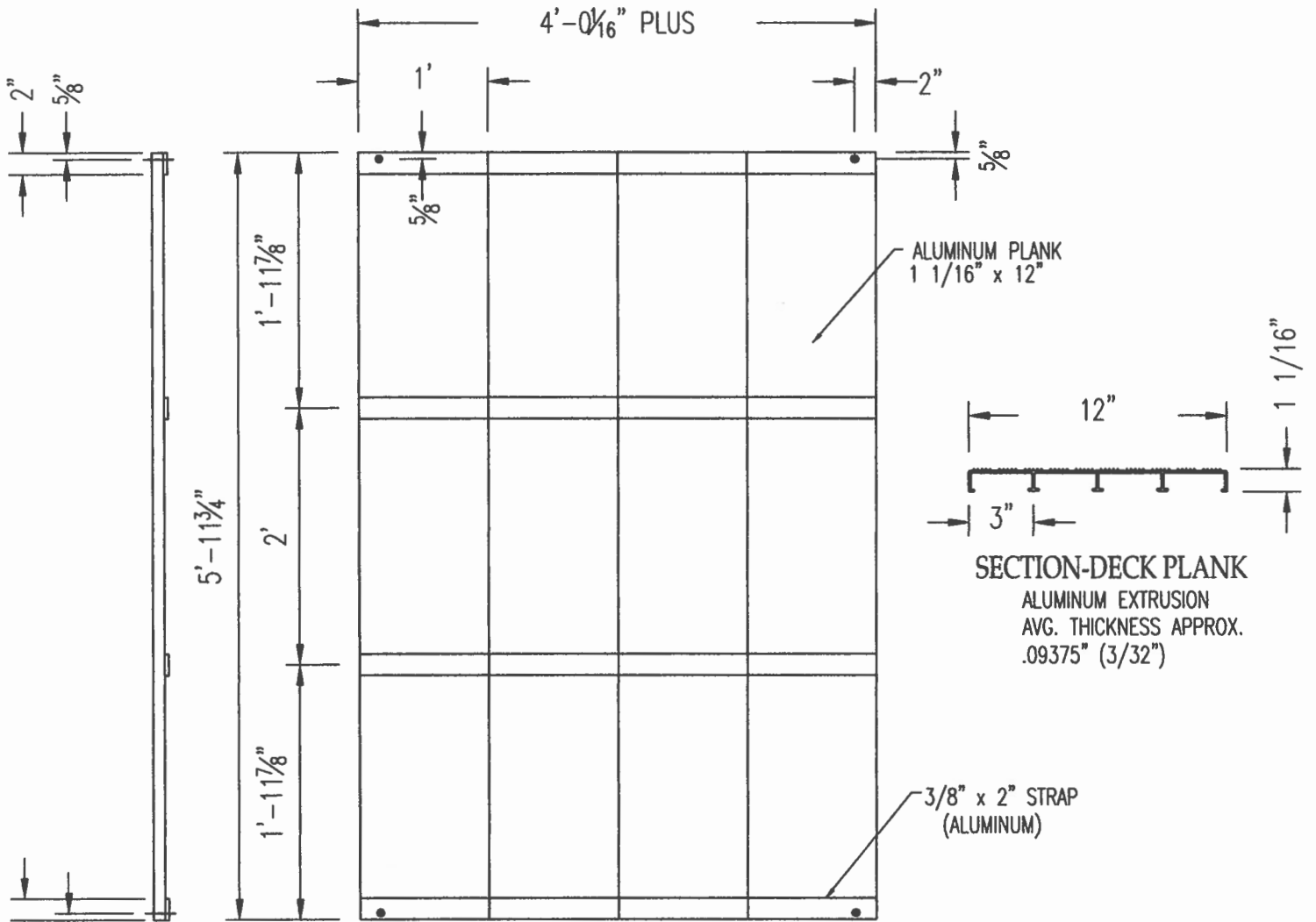

TOP VIEW

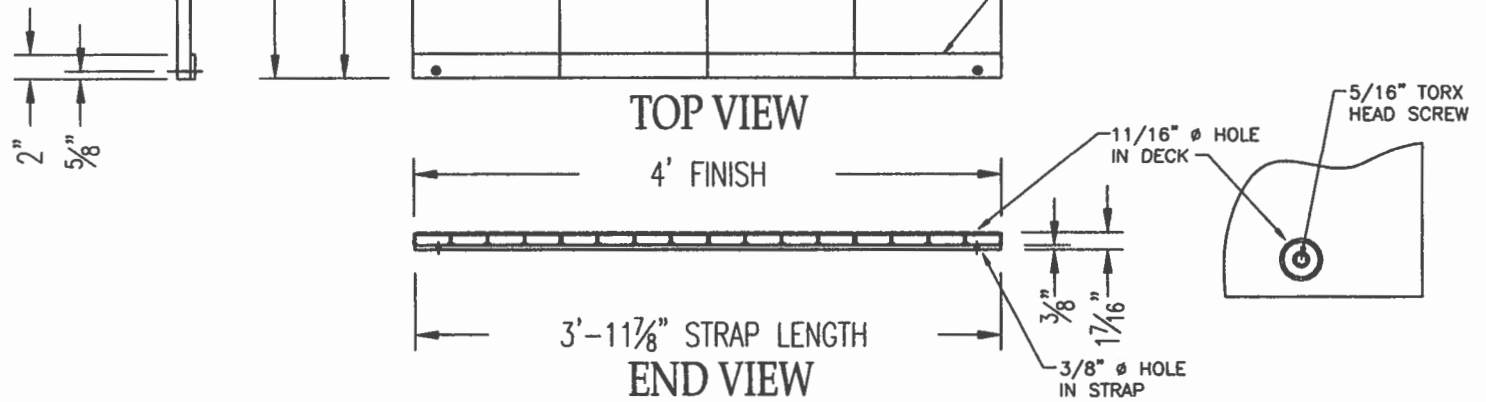

Mokkarala
Prakash

Digitally signed by
Mokkarala Prakash
Date: 2026.05.22
02:24:34 -05'00'

JOB: THE CLIFFS - BRIDGE

DATE: 05/05/26

MAKE: 1

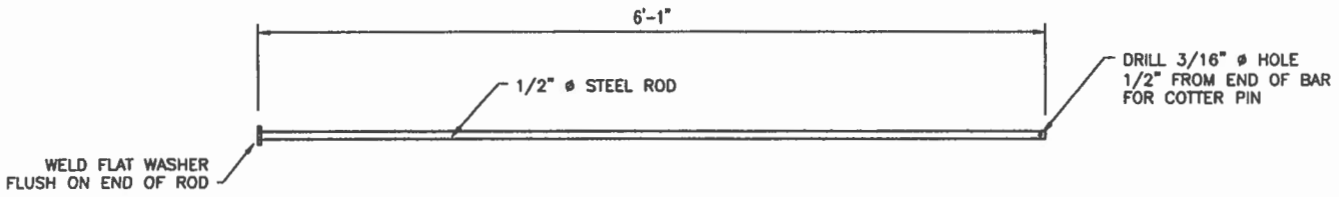

Mokkarala
Prakash

Digitally signed by
Mokkarala Prakash
Date: 2026.05.22 02:25:49
-05'00'

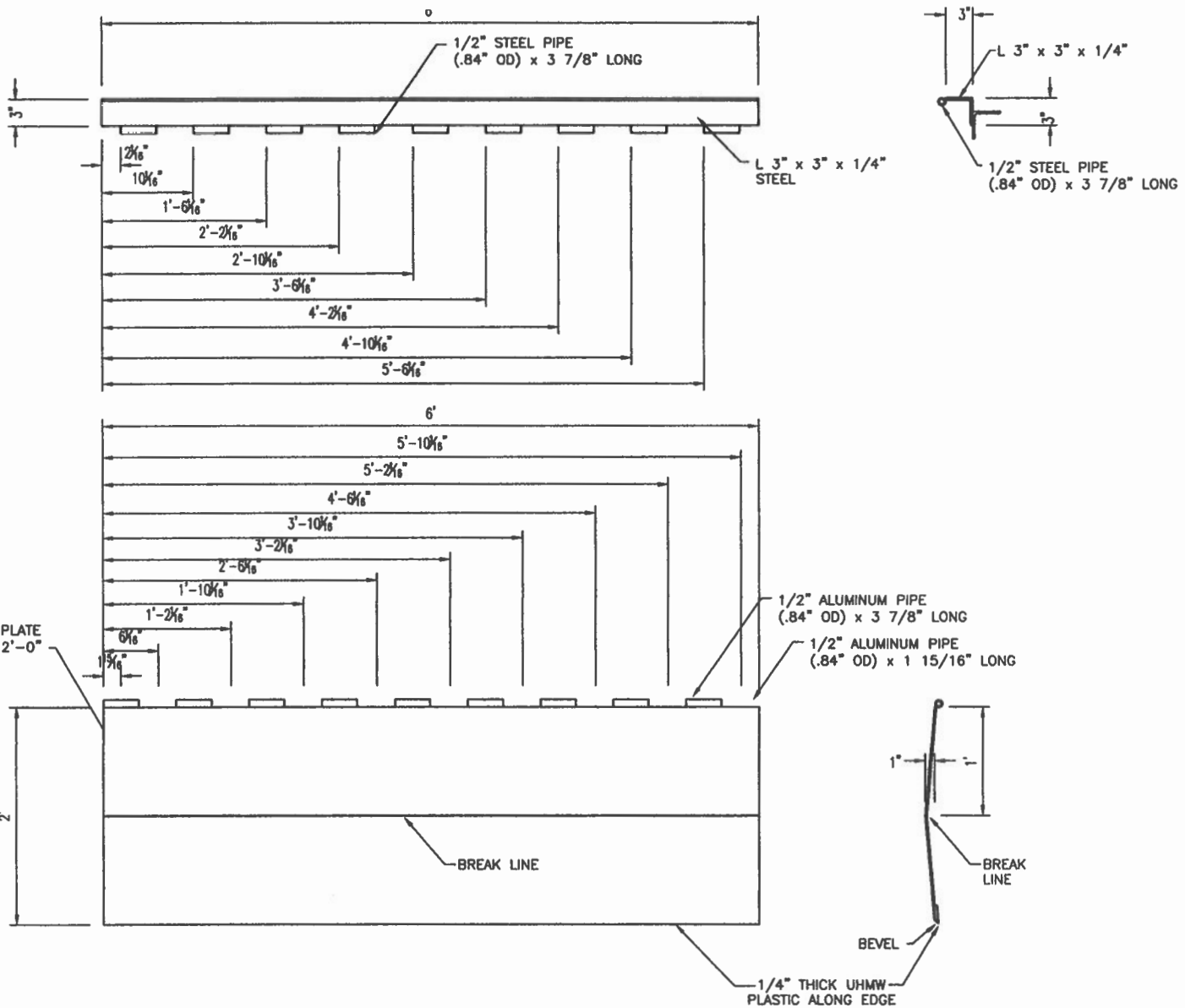

HINGE PLATE

JOB: THE CLIFFS - BRIDGE

DATE: 05/05/26

MAKE: 1

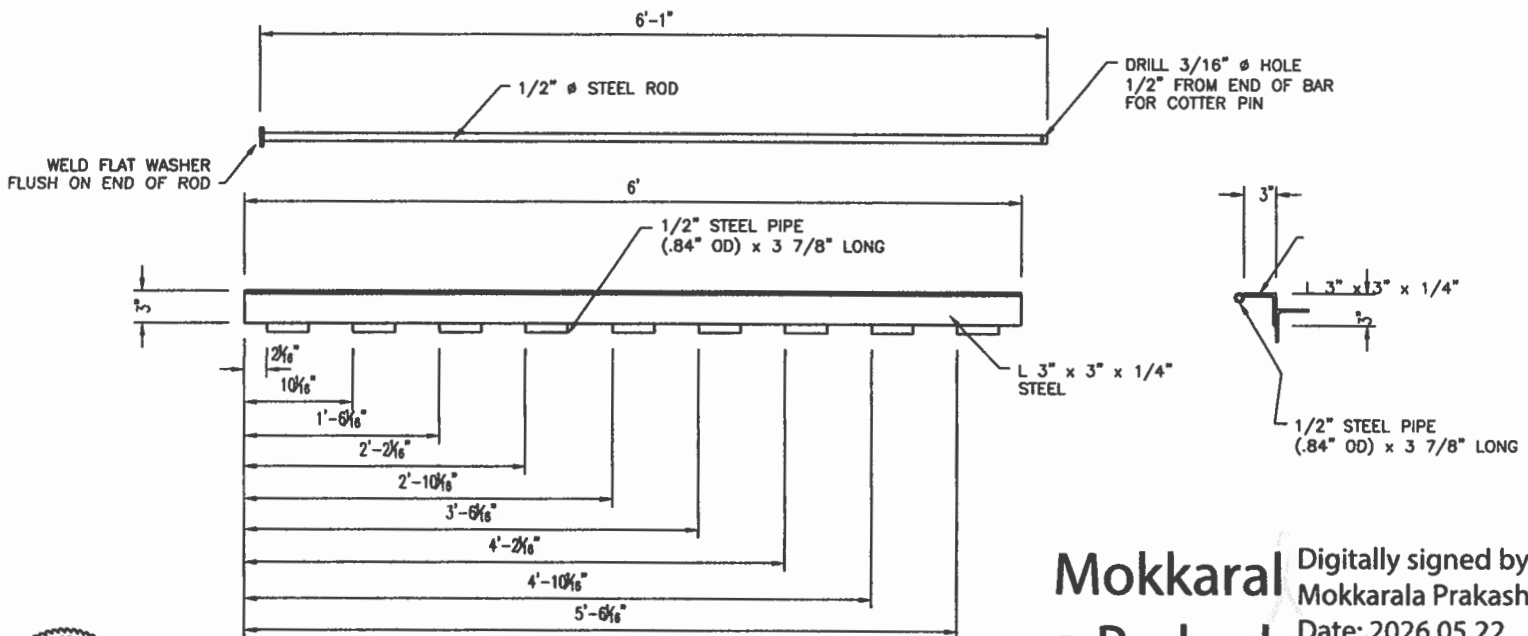

Mokkaral Digitally signed by Mokkarala Prakash
a Prakash Date: 2026.05.22
02:27:09 -05'00'

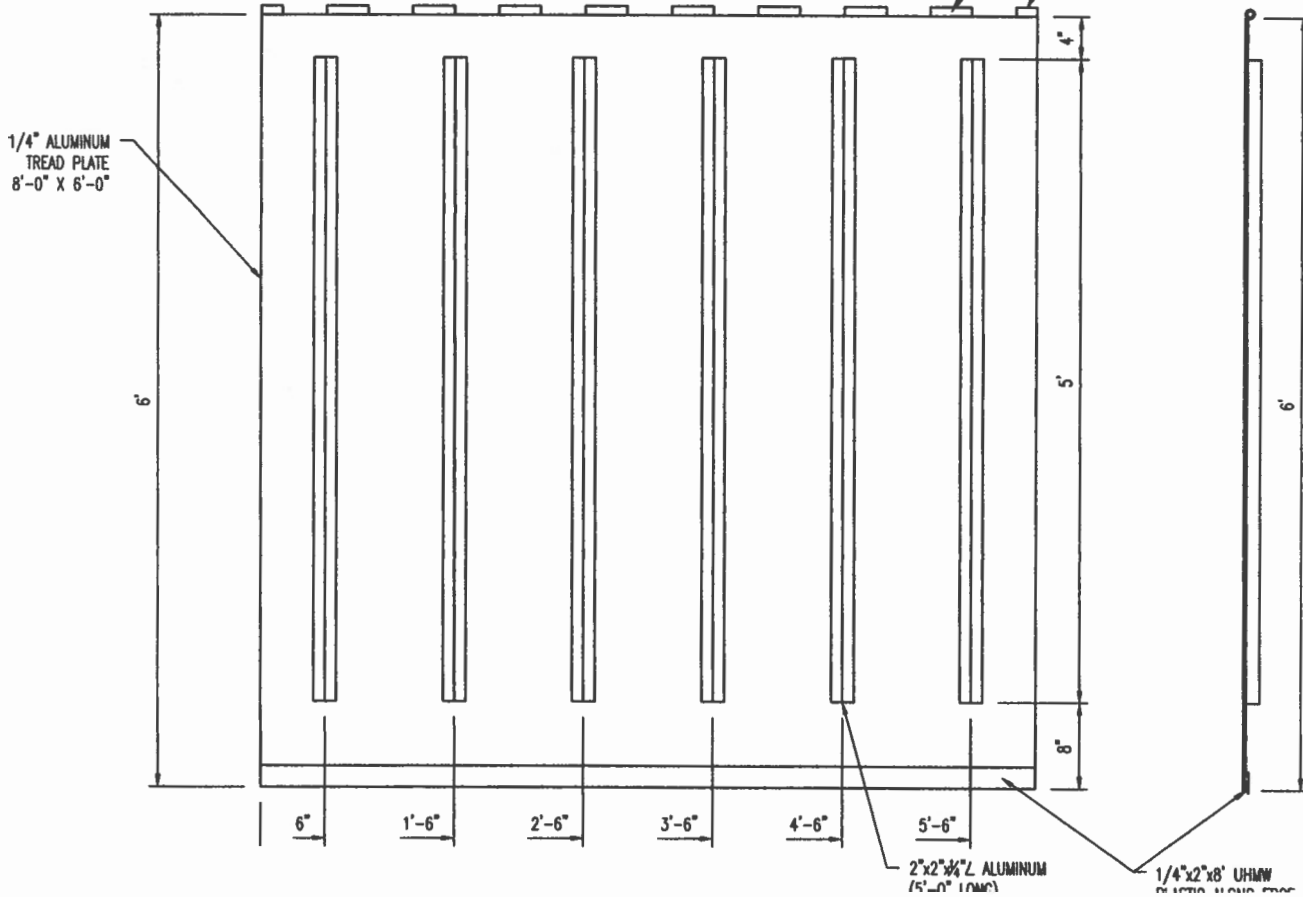
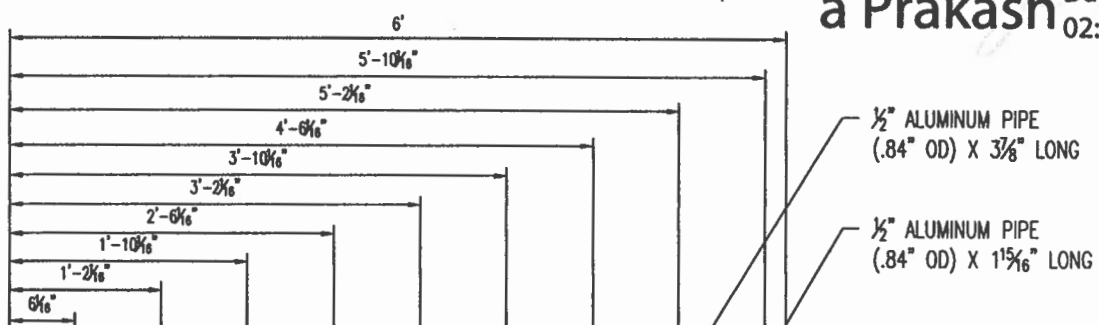

NAME: THE CLIFFS
 DATE: 05/05/26

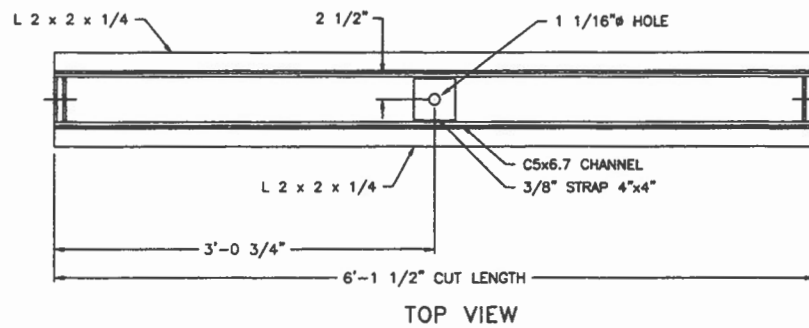
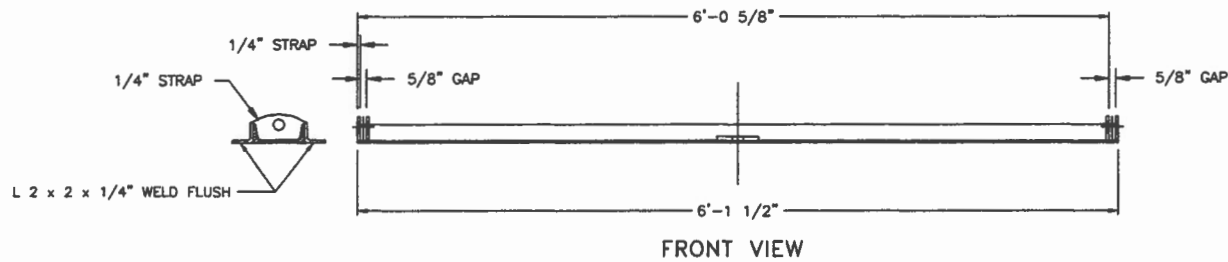
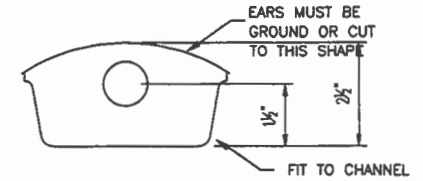
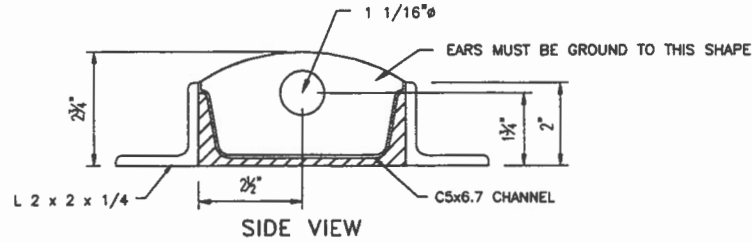

BRIDGE TO DOCK 5TH WHEEL TURN PLATE
 (1) ASSEMBLY REQ'D. GALV.

Mokkaral
 a Prakash

Digitally signed by
 Mokkarala Prakash
 Date: 2026.05.22
 02:28:32 -05'00'



BRIDGE ROLLER END

NAME: THE CLIFFS - BRIDGE

DATE: 05/05/26

**Mokkaral
a Prakash** Digitally signed by
Mokkarala Prakash
Date: 2026.05.22
02:32:47 -05'00'

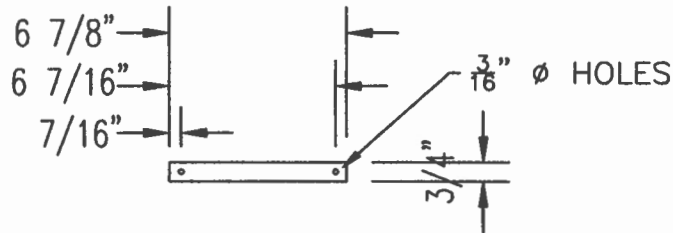
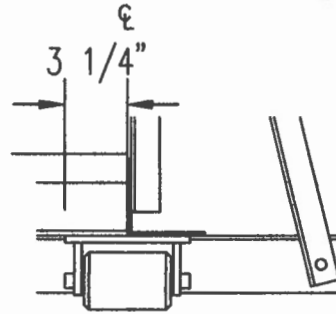
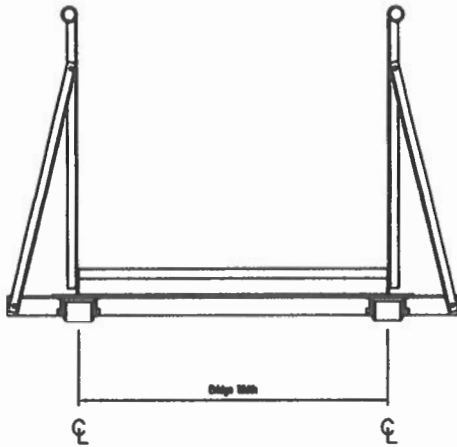

ROLLER PIN

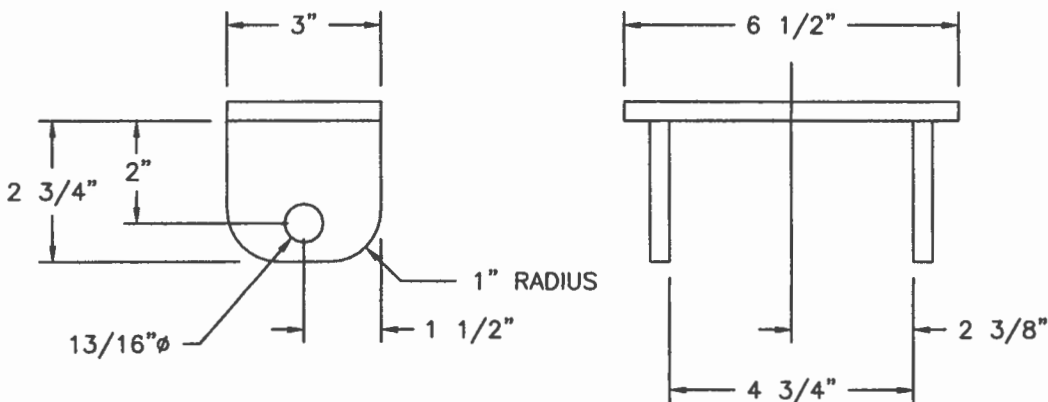

BRIDGE ROLLER BRACKET

MATERIAL: $3/8'' \times 3''$ STRAP

QTY REQ'D: 1

STANDARD BRIDGE (2 1/2"Ø PIPE TOP RAIL)

NAME: THE CLIFFS - BRIDGE

DATE: 05/05/26

Mokkarala Prakash

Digitally signed by Mokkarala Prakash

Date: 2026.05.22 02:34:13 -05'00'

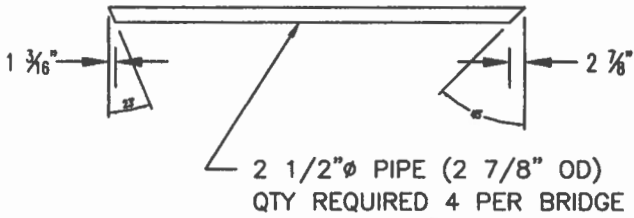
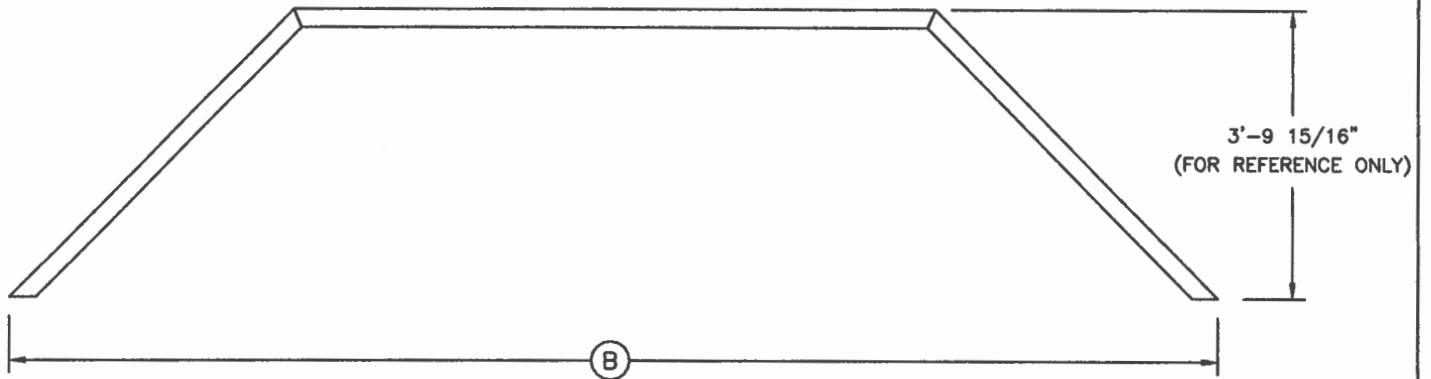
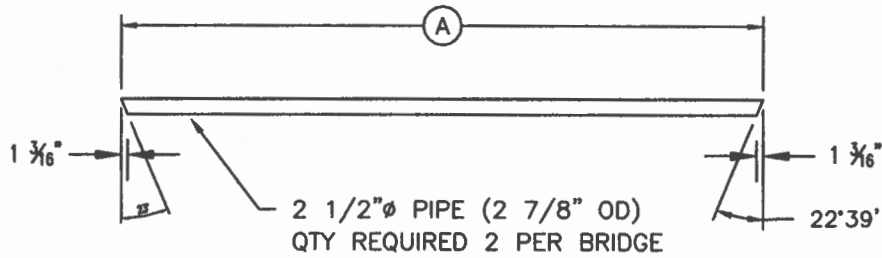

| BRIDGE LENGTH | A | B (REF) |
|---------------|--------|---------|
| | | |
| | | |
| | | |
| 40' | 32'-2" | 39'-9" |

NEED 2 RAILS FOR 1 BRIDGE